

SELF-PILOTING NUT WELDING ELECTRODES



Phone: 888-654-9353 Fax: 937-253-2324 Production Engineering Sales Co.

SELF-PILOTING NUT WELDING ELECTRODES



PART No.	Taper Size	Pin Dia. N	For Nut Thread Size	Pin Length L
16-3764-04	5 RW	.082	#4	.093
16-3764-05		.093	#5	
16-3764-06		.100	#6	
16-3764-M3.5		.107	3.5 MM	
16-3764-M4	5 RW	.123	4.0 MM	.156
16-3764-08		.129	#8	
16-3764-10		.143	#10	
16-3764-M5		.156	5.0 MM	

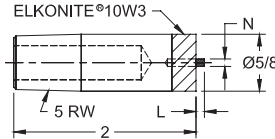

FEATURES AND SPECIFICATIONS

- ELKONITE®10W3 faced CMW® 3 material
- Insulated pin made of anodized aluminum
- Pins are treated to 55 HRC for wear resistance
- Use with tapered electrode holders
- Use with flat faced electrodes

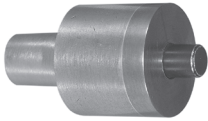

PART No.	Taper Size	Pin Dia. N	For Nut Thread Size	Pin Length L
16-3765-12	5 RW	.166	#12	.375
16-3765-M6		.189	6.0 MM	
16-3765-25		.192	1/4	
16-3765-M7		.223	7.0 MM	
16-3765-M8	5 RW	.252	8.0 MM	.375
16-3765-31		.257	5/16	
16-3765-M9		.291	9.0 MM	

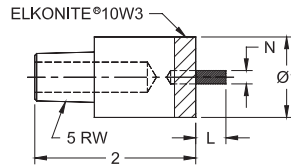

TYPICAL SET-UP FOR SELF PILOTING NUTS

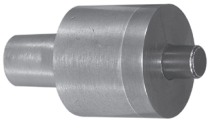
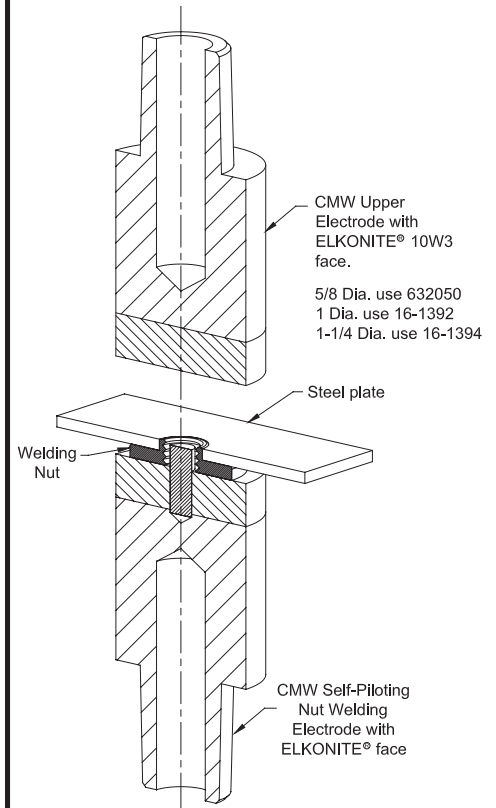

PART No.	Taper Size	Pin Dia. N	For Nut Thread Size	Pin Length L
16-3766-38	5 RW	.306	3/8	.375
16-3766-M10		.320	10 MM	
16-3766-M11		.359	11 MM	
16-3766-44	5 RW	.361	7/16	.375
16-3766-M12		.388	12 MM	
16-3766-50		.415	1/2	
16-3766-M14		.455	14 MM	

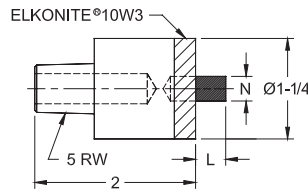

- See page 6 for Metric conversions
- See page 7 for Taper dimensions